



**GWF**  
GREENWOOD FENCE



CATALOG 2026



## Welcome to Greenwood Fence

Step into a world where design meets durability - welcome to Greenwood Fence's 2026 Catalog. As a beacon of innovation since 2019, we're excited to guide you through our curated collection of state-of-the-art composite fencing solutions. Our catalog is more than just a showcase of products; it's an invitation to transform spaces with elegance and strength. Each page unfolds our commitment to sustainability, quality, and the kind of customer experience that turns first-time inquiries into lasting partnerships. Dive in and discover the perfect blend of style, security, and sustainability for your next project.



## What is a Greenwood Fence?

Greenwood Fence presents a durable composite fencing system combining wood plastic composite boards with stylish aluminum posts and rails. This elegant yet functional solution enhances any outdoor setting. Our Advanced Series boards are sustainably made from recycled materials, offering high density and durability, with a protective shield for longevity and low maintenance. Our commitment lies in innovative design, exceptional customer support, and ensuring our clients receive enduring value and quality that defines our brand.

FOLLOW US



### CLASSIC PRIVACY



Wind loading



Warranty



Eco-friendly

### CLASSIC DELUXE PRIVACY



Low maintenance



Waterproof



Anti-UV

### DELUXE SEMI PRIVACY



### HORIZONTAL PICKET



DELUXE TRELLIS



Wind loading



Warranty



Eco-friendly

CLASSIC TRELLIS



Low maintenance



Waterproof



Anti-UV

LATTICE SEMI PRIVACY



MODERN PRIVACY



### CLASSIC SEMI PRIVACY



Wind loading



Warranty



Eco-friendly

### ELITE PRIVACY



Low maintenance



Waterproof



Anti-UV

### ELITE DELUXE PRIVACY



### ALUMINUM EUROFENCE



### ALUMINUM LEAF LATTICE



Wind loading



Warranty



Eco-friendly

### ALUMINUM WAVEFORM LATTICE



Low maintenance



Waterproof



Anti-UV

### ALUMINUM DOUBLE LATTICE



### ALUMINUM CLASSIC PRIVACY



# PRIVACY AS AN ART FORM



A fence defines space; architecture defines experience. Transform your property line from a simple barrier into a permanent design statement. Our aluminum collection creates a seamless, curated backdrop for your life, making your outdoor room as serene as it is secure.



**FEATURES**



**CREATIVITY  
WITH  
COMPOSITE  
FENCING**



**A FENCE FOR EVERY VISION:**

EMBRACE THE VERSATILITY OF A CUSTOMIZABLE GREENWOOD FENCE

**PARTS**



**MODULAR FENCE ELEMENTS**

**Capped Composite - Easy Install**



The GWF® Modular Fence System is engineered for ultimate versatility and style. It features robust aluminum posts, interlocking rails, composite and vinyl tongue-and-groove panels - with composite boards enhanced by a capped polymer shield - delivering a fencing solution that's as durable as it is sleek. Its modular design ensures rapid installation while maintaining a consistently secure, refined finish. This innovative system empowers you to tailor your fence to match any privacy or aesthetic preference. Whether you're aiming for complete seclusion or a defined, elegant boundary, the GWF® system adapts effortlessly to your vision, blending advanced materials with flexible design to create a fence built to your exact needs.

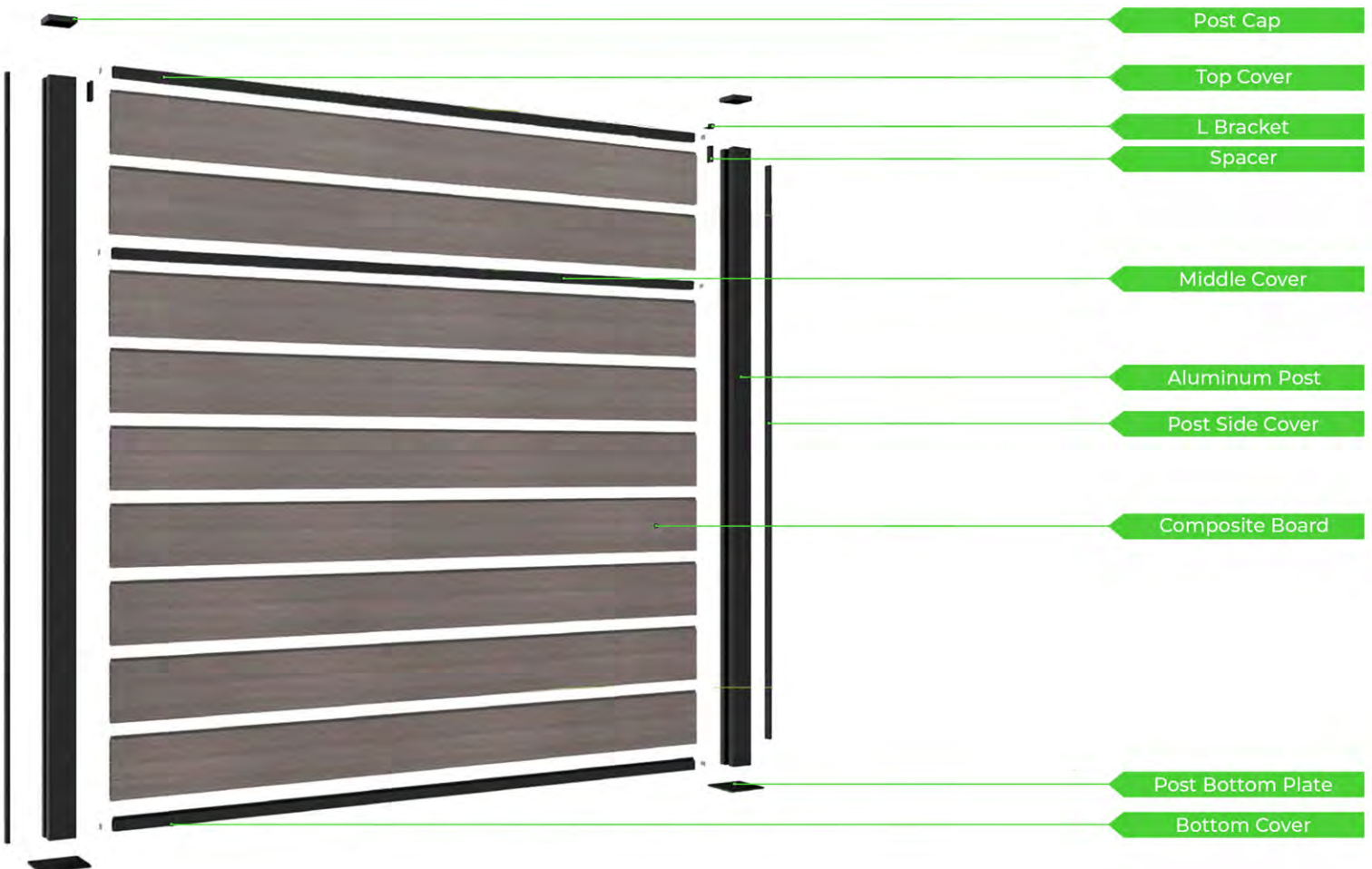

**SWIVEL KIT**

**ADJUSTABLE ANGLE POST**

**Different Angles, Different Applications**

Now with these new aluminum parts, our fence system can be adjusted to very specific angles to accomodate many requirements of different applications.

An axis is inserted into the slot of the post, and the pivot slides over it. The pivot will receive the fence board like a normal line post.



GWF513ASKB

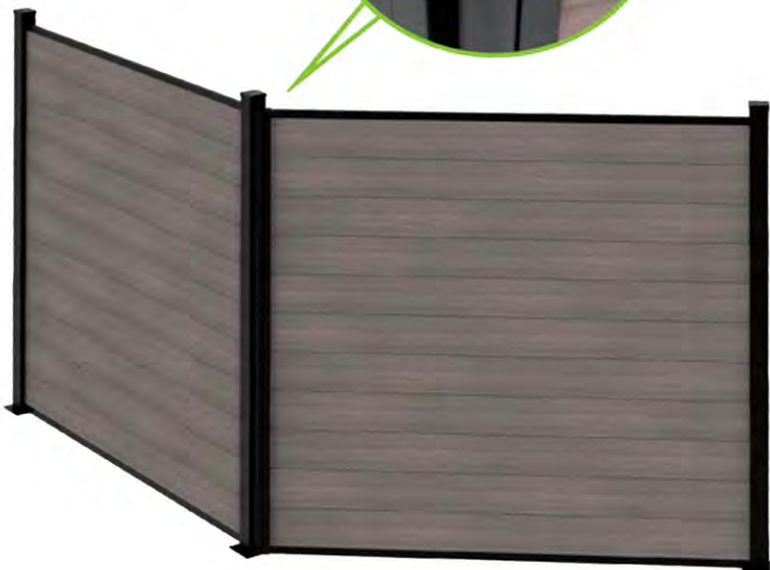
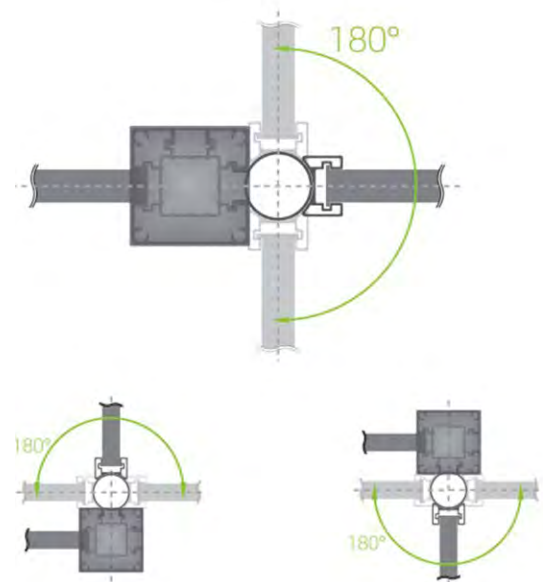

**GATES**

**Elevate your Space with  
Elegance and Strength**

Innovative Aluminum and  
Composite Gate Solutions  
for the Modern World



Available now at  
[greenwoodfence.com](http://greenwoodfence.com)

## GATES

**Introducing the GWF Gate Series: Where Elegance Meets Innovation**

Crafted for sophistication and designed to last, the GWF Gate Series sets the standard for modern entry solutions. Our gates offer a harmonious blend of durability and low maintenance, ensuring they stand the test of time while maintaining their pristine appearance.

**Sleek Design**

Each 4-foot-wide gate frame is engineered to accommodate composite, vinyl or aluminum tongue and groove interlocking boards, ensuring a sleek, coherent look. The seamless frame design conceals hardware and eliminates weld marks, providing a flawless finish that complements any property.

**Durability and Quality**

Constructed from robust 6063 T6 aluminum alloy, our gates are not just strong but also lightweight. The Qualicoat Certified powder coating process ensures a uniform, durable matte black finish that resists the elements and daily wear. Our commitment to quality means your gate will maintain its integrity and appearance for years to come.

**Colorful Customization**

Choose from eight distinctive colors for board infills to match your style or branding. The full privacy design provides complete seclusion, while the flexible structure allows for semi-privacy customizations to suit your aesthetic and functional preferences.

**Optimized Functionality**

The 6-foot single and 12-foot double swing gates echo the design principles of the 4-foot model but are exclusively paired with our sleek aluminum or vinyl boards only. This choice not only enhances the visual appeal but also optimizes functionality by maintaining a lighter load, ensuring smooth operation every time.



**GATE POST**

**THE “NO DIG” WALL MOUNT 2” x 3” GATE POST**

**Expertly Engineered for Distinctive Spaces**

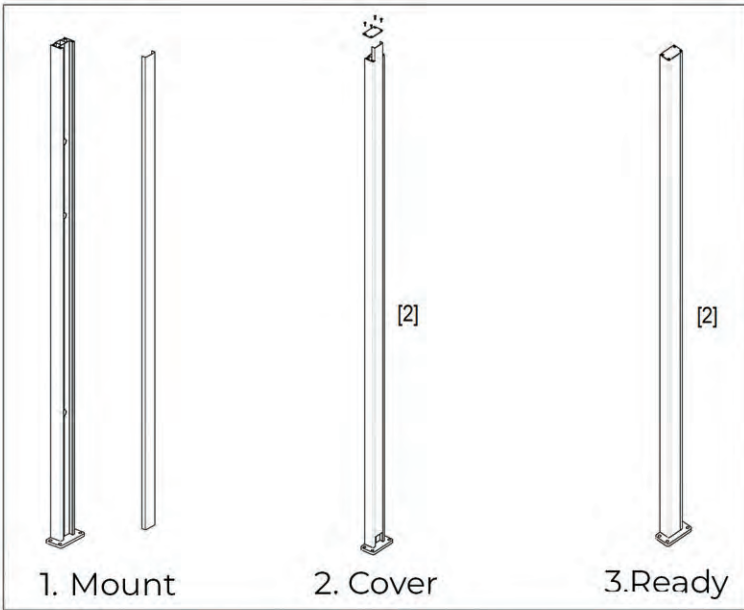

Engineered for convenience and durability, the **2”x3”** GWF Wall Mount Gate Post integrates seamlessly with our GWF gate series. Its sleek aluminum profile saves space and mounts directly to brick or concrete - **no digging required** -ensuring a clean, unified look that blends perfectly with your gate and surroundings.

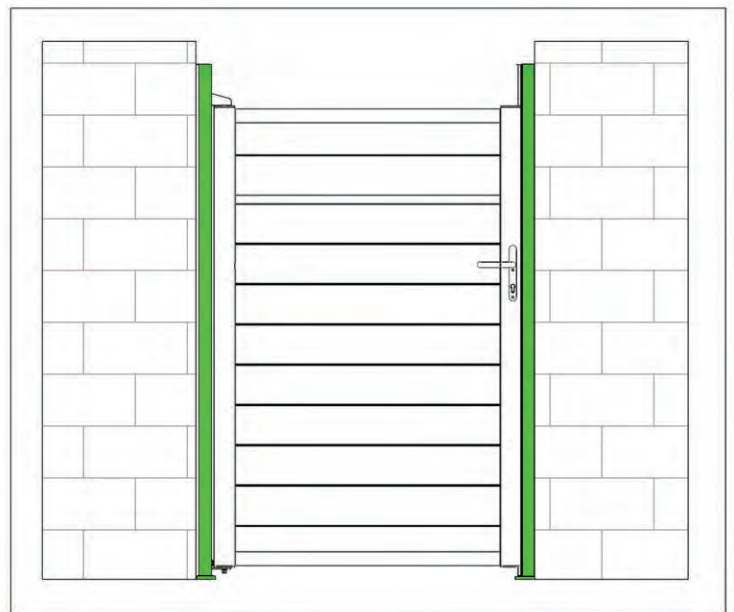

- **Space-Saving Slim Design:** Fits narrow openings while maintaining a sturdy, reliable support.
- **No-Dig Installation:** Mounts directly on masonry or concrete surfaces for a quicker, cleaner install.
- **Seamless Aesthetic:** Sleek aluminum post is designed to match the modern lines of our GWF gate.
- **Engineered Strength:** Built to handle everyday use, weather, and gate operations without sacrificing style.

**GATE PARTS**

**THE “GAPLESS GATE” GWF GAP CLOSER**

**Where Entryways Become Statements**

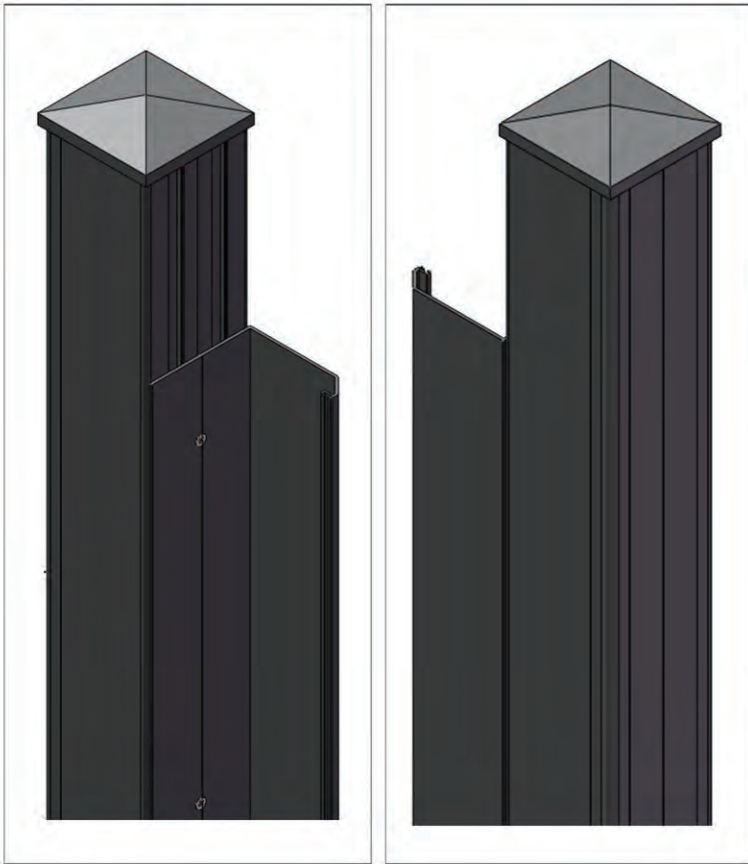

Eliminate the hinge-side opening with the GWF Gap Closer. Designed to run the full length of our standard 4"×4" or 6"×6" gate posts, it seamlessly conceals any clearance required for hinges—ensuring a sleek, uninterrupted look that transforms your gate into a truly “gapless” solution.



- **Sleek Aesthetic:** Creates a clean, modern appearance by covering the hinge gap completely.
- **Engineered Fit:** Purpose-built for GWF Gate systems to ensure perfect integration and consistent styling.
- **Enhanced Privacy:** Minimizes gaps, adding an extra layer of coverage and security.
- **Universal Compatibility:** Works with both 4"×4" and 6"×6" GWF gate posts.

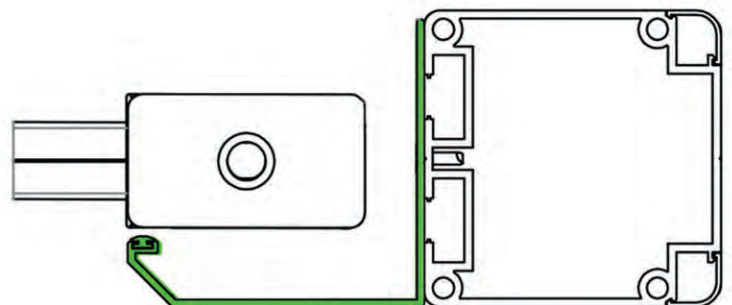

# GWF Premium Vinyl Series

*Vinyl Fence, Perfected to an Unprecedented Standard of Excellence and Innovation.*

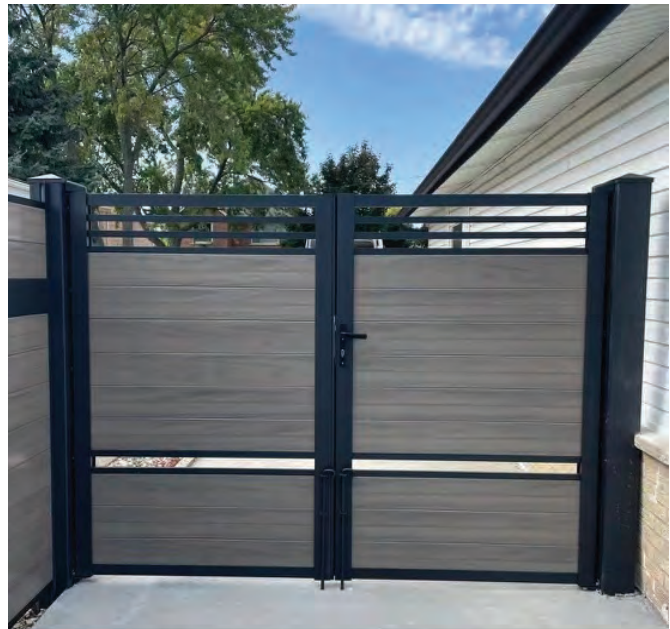

Elevate your property with the GWF Premium Vinyl Fence - designed for lasting beauty, strength, and **low maintenance**. Combining durable vinyl with sleek aluminum framing, this versatile fence offers the perfect balance of aesthetic appeal and weather resistance, making it suitable for both residential and commercial applications.

- **Durable & Stylish:** Tongue-and-groove vinyl boards paired with robust aluminum framing for a smooth, continuous look.
- **Cost-Effective:** A high-quality alternative to WPC, offering long-term durability at a competitive price.
- **Versatile Installation:** Easy-to-install, customizable system to suit any height or layout.
- **Premium Grade:** Meets both residential and commercial standards for strength and performance.
- **Sustainable Choice:** Built to last, reducing the need for frequent replacements.

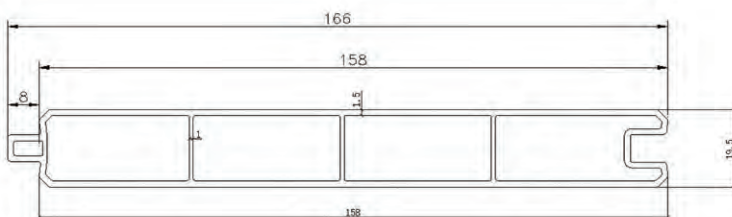

**ALUMINUM**



# GWF Aluminum Euro Slat Fence

*Tailored Style & Privacy for the Modern World*



- **Customizable Slat Spacing:** Adjust slats to any size for tailored aesthetics and privacy.
- **Durable & Low Maintenance:** Constructed from high-quality 6063 aluminum for long-lasting performance.
- **Seamless Integration:** Compatible with the GWF modular fence system for easy assembly.
- **Modern Design:** Clean lines and a sophisticated finish to complement contemporary landscapes.

Available now at [greenwoodfence.com](http://greenwoodfence.com)

ALUMINUM EURO FENCE (6 X 6)  
(4-1/8" SLATS, 1" SPACING)

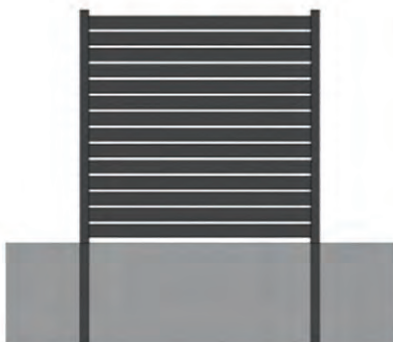

ALUMINUM EURO FENCE (5 X 6)  
(4-1/8" SLATS, 2" SPACING)





## PROTECTING FENCE POSTS FROM CONCRETE SPLATTER

One of the easiest ways to ruin the clean look of a fence installation is through concrete splatter or dust settling on your posts while setting them in place. When wet concrete cures on the surface, it can bond to the finish, creating white stains or rough patches that are difficult to remove without damaging the coating. Aesthetically, it's a nightmare — and practically, it can mean extra time, cost, and frustration on the job site.

## HOW GREENWOOD FENCE PREVENTS CONCRETE DAMAGE

At Greenwood Fence, we understand that even the smallest installation detail can make a big difference. That's why all Greenwood Fence posts and rails are protected with a **removable plastic film on all sides**. This simple but effective feature shields the aluminum surfaces from dust, debris, and concrete splatter during installation.

Once the concrete has fully cured, installers can easily peel away the protective film to reveal a **clean, undamaged, and professional finish**. No sanding, no chemical cleaners, and no risk of marring the surface coating.

## WHY THIS MATTERS

**Professional Finish:** No residue or rough patches left behind after setting posts.

**Time-Saving:** No need for chemical cleaning or scrubbing concrete buildup.

**Cost-Effective:** Reduces the chance of damage and rework, keeping projects on budget.

**Installer Friendly:** Just peel and reveal — it's that simple.

## SMART DESIGN FOR SMOOTH INSTALLATIONS

This thoughtful detail is just one of many ways Greenwood Fence makes installation faster, cleaner, and more reliable for professionals and DIY installers alike. From gates and modular components to commercial fencing solutions, every part of our system is engineered to perform beautifully in the real world — saving time without sacrificing quality.

WHETHER YOU'RE A CONTRACTOR OR HOMEOWNER, EVERY GREENWOOD FENCE INSTALLATION STARTS WITH SMARTER DESIGN AND ENDS WITH A FLAWLESS FINISH.



# COMPANY SPOTLIGHT: GREENWOOD FENCE



## Industry Spotlight

**Greenwood Fence's growth, product innovation, and market leadership were recently highlighted in Fence News.**

Greenwood Fence's story began in 2019 with the opening of a single 500-square-foot showroom on a busy Chicago street corner. At the time, composite fencing was virtually unknown to most homeowners. But once customers could see and touch the product, and understand that modern design, durability, and low maintenance didn't have to be mutually exclusive, interest quickly turned into demand.

That early response validated the concept. Within the company's first year, approximately 85% of sales came from retail homeowners. But the three partner/owners soon recognized a larger opportunity. While the showroom proved the product's appeal, long-term growth would depend on putting Greenwood Fence systems into the hands of contractors, distributors, and fence companies nationwide.

That shift became a defining moment. Greenwood Fence transitioned from a retail-first model into a contractor-driven operation, and growth accelerated. Today, roughly 90 percent of sales flow through professional partners, supported by an active national network of more than 1,000 contractors and distributors. Products have now shipped to every U.S. state, with select distribution into Canada.

Facility growth followed demand. Greenwood Fence expanded from 5,500 square feet to 12,000, and then to its current 18,000-square-foot warehouse and showroom footprint – each move triggered by increased sales, deeper inventory needs, higher fulfillment volume, staff growth and showroom traffic. Plans are already underway for another expansion, doubling the company's footprint to support continued residential growth and its recently launched commercial division.

At the core of Greenwood Fence's success is product discipline. Rather than relying on marketing claims, the company has built its reputation on third-party testing and validation through organizations such as SGS and Intertek. Products undergo rigorous testing for wind load, strength, water absorption, simulated weathering and environmental compliance, with powder coating standards aligned with Qualicoat Class 2 and AAMA 2604. Quality control extends to random container inspections and checks on every component prior to shipment.

The product ecosystem has grown just as intentionally. Greenwood Fence now offers approximately 300 component SKUs and more than 70 finished product SKUs, designed as a complete system rather than standalone parts. Innovation milestones include a climate-adaptive gate and post system engineered to accommodate seasonal movement, as well as the upcoming launch of the GWF Aluminum Collection, which preserves Greenwood Fence's design language while meeting non-combustible requirements.

National visibility has followed. In 2022, Greenwood Fence was discovered through organic social growth and featured in two HGTV Inside Out episodes, showcasing modular composite fencing in real-world installations. Strategic creator partnerships helped expand awareness beyond the Midwest, fueling broader contractor adoption. Retail expansion has been equally deliberate, with Greenwood Fence currently available in 15 Home Depot states; launched regionally first, then scaled outward.

Despite its growth, Greenwood Fence continues to differentiate itself through service. Typical ship lead times average three to five days, with transit ranging from four to nine days depending on location. More importantly, every order is inspected before leaving the warehouse, and contractors receive hands-on support throughout quoting, design, and installation. From a single showroom to a nationwide network, Greenwood Fence has grown by listening, testing, refining and releasing, proving that scale, innovation, and partnership can coexist in a category ready for modern thinking.

Learn more at [greenwoodfence.com](http://greenwoodfence.com).



# CONTACT US

[WWW.GREENWOODFENCE.COM](http://WWW.GREENWOODFENCE.COM)

[INFO@GREENWOODFENCE.COM](mailto:INFO@GREENWOODFENCE.COM)

1-888-24FENCE

